

## GRF5611

### HIGH LINEARITY POWER AMPLIFIER

#### 902 to 960 MHz

#### FEATURES

- Excellent OP1dB, OIP3, ACLR and IM3 Performance
- Native Linearity Provides up to 26 dBm P<sub>OUT</sub> with > 45 dBc ACLR Without the Need for Digital Predistortion Correction
- 25.5 dBm Linear Output Power Maintained at 85 °C
- Flexible Biasing Provides Latitude for Linearity Optimization
- 207 mA Native Mode Quiescent Current Consumption
- 5 V Supply Voltage
- 50 Ω Single-Ended Input and Output Impedance
- Digital Shutdown
- Rugged Design is Extremely Resilient to Mismatched Loads
- -40 to 85 °C Operating Temperature Range
- Compact 3 x 3 mm QFN Package

**Reference: 5 V / 207 mA I<sub>CCQ</sub> / 925 MHz**

- Gain: 26.3 dBm
- OIP3: 46.9 dBm @ 25 dBm P<sub>OUT</sub>/tone
- OP1dB: 34.9 dBm
- Evaluation Board Noise Figure: 4.1 dB

#### APPLICATIONS

- Cellular Boosters
- Automotive Compensators
- Picocells/Femtocells
- Customer Premise Equipment
- RFID

 **ORDERING INFORMATION**  
Buy it Now

#### DESCRIPTION

The GRF5611 is a high gain, two-stage InGaP HBT Power Amplifier designed to deliver excellent P1dB, ACLR and IM3 performance over the 902 to 960 MHz band. Its exceptional native linearity makes it an ideal choice for transmitter applications that typically do not employ digital predistortion correction schemes.

This device is part of a complete family of externally matched linear amplifiers that cover the following frequency ranges:

- [GRF5605](#): 617 - 652 MHz    [GRF5610](#): 860 - 928 MHz
- [GRF5606](#): 663 - 716 MHz    [GRF5611](#): 902 - 960 MHz
- [GRF5607](#): 703 - 748 MHz    [GRF5616](#): 1625 - 1675 MHz
- [GRF5608](#): 729 - 830 MHz    [GRF5617](#): 1710 - 1785 MHz
- [GRF5609](#): 814 - 862 MHz    [GRF5618](#): 1800 - 1920 MHz

Please consult with the GRF applications engineering team for custom tuning/evaluation board data.

#### BLOCK DIAGRAM

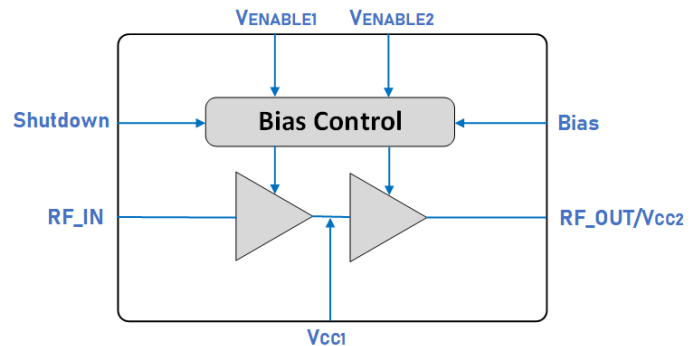

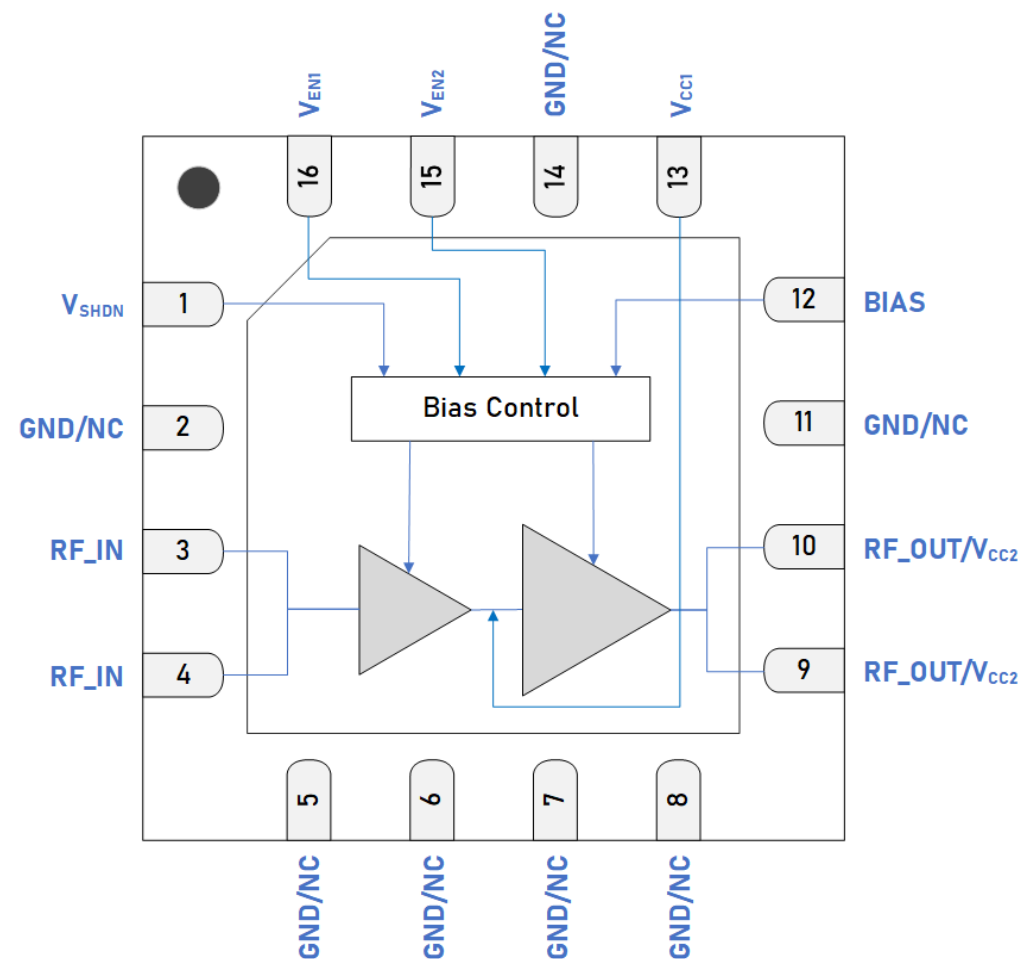

Pin Out (Top View)

## Pin Assignments

Pin	Name	Description	Note
1	V <sub>SHDN</sub>	Digital Shutdown Pin	V <sub>SHDN</sub> ≥ 1.5 V (Logic HIGH) disables device. V <sub>SHDN</sub> ≤ 0.9 V (Logic LOW) enables device.
2, 5, 6, 7, 8, 11, 14	GND/NC	Ground or No Connect	No internal connection to die. These pins can be left unconnected, or be connected to ground (recommended). Use a via as close to the pin as possible if grounded.
3, 4	RF_IN	RF Input	Pins 3 and 4 tied together on system board. An external DC blocking capacitor must be used.
9, 10	RF_OUT/V <sub>CC2</sub>	PA Output/Bias Voltage	Pins 9 and 10 tied together on system board. V <sub>CC2</sub> must be applied to this pin via an RF choke.
12	Bias	Bias Circuit Supply	Connect to V <sub>CC2</sub> through external resistor.
13	V <sub>CC1</sub>	Bias Voltage	Connect to V <sub>CC1</sub> through external inductor or 0 Ω resistor.
15	V <sub>EN2</sub>	Enable2 Voltage Input	V <sub>EN2</sub> and series resistor set I <sub>CCQ</sub> for the output stage. V <sub>EN2</sub> ≤ 0.2 volts disables stage 2.
16	V <sub>EN1</sub>	Enable1 Voltage Input	V <sub>EN1</sub> and series resistor set I <sub>CCQ</sub> for the input stage. V <sub>EN1</sub> ≤ 0.2 volts disables stage 1. Connecting an external de-coupling capacitor to ground is required for optimal NF performance.
PKG BASE	GND	Ground	Provides DC and RF ground for the amplifier, as well as thermal heat sink. Recommend multiple 8 mil vias beneath the package for optimal RF and thermal performance. Refer to evaluation board top layer graphic on schematic page.



## Truth Table

Pin	Logic Level	Condition
$V_{SHDN}$	LOW	Full Operation
	HIGH	All Amplifiers OFF
$V_{EN1}$	LOW	Stage 1 Amplifier OFF
	HIGH	Stage 1 Amplifier ON
$V_{EN2}$	LOW	Stage 2 Amplifier OFF
	HIGH	Stage 2 Amplifier ON

## Absolute Ratings

Parameter	Symbol	Min.	Max.	Unit
Supply Voltage	$V_{CC}$		TBD	V
RF Input Power: 50 $\Omega$ , $V_{CC} = 5$ V, CW tone, 100 % duty cycle, $T_{PKG\ BASE} = 25$ °C.	$P_{IN\ MAX: 1:1}$		TBD	dBm
RF Input Power: Load VSWR $\leq 8:1$ , all phase angles, $V_{CC} = 5$ V, CW tone, 100% duty cycle, $T_{PKG\ BASE} = -40$ to 85 °C.	$P_{IN\ MAX: 8:1}$		TBD	dBm
Operating Temperature (Package Base)	$T_{PKG\ BASE}$	-40	85	°C
Maximum Junction Temperature (MTTF > 10 <sup>6</sup> Hours)	$T_{J\ MAX}$		170	°C
Maximum Dissipated Power (Stage 1)	$P_{DISS\ MAX}$		TBD	mW
Maximum Dissipated Power (Stage 2)	$P_{DISS\ MAX}$		TBD	mW
Shutdown Voltage	$V_{SHDN}$		TBD	V

## Electrostatic Discharge

Charged Device Model	CDM	750		V
Human Body Model	HBM	1000		V

## Storage

Storage Temperature	$T_{STG}$	-65	150	°C
Moisture Sensitivity Level	MSL		1	--



**Caution! ESD Sensitive Device.**

**Exceeding Absolute Maximum Rating conditions may cause permanent damage.**

Note: For additional information, please refer to [Manufacturing Note MN-001 - Packaging and Manufacturing Information](#).



All Guerrilla RF products are provided in RoHS compliant lead (Pb)-free packaging. For additional information, please refer to the [Certificate of RoHS Compliance](#).



## Recommended Operating Conditions

Parameter	Symbol	Specification			Unit	Condition
		Min.	Typ.	Max.		
Supply Voltage	$V_{CC}$	TBD	5	TBD	V	
Operating Temperature Range	$T_{PKG\ BASE}$	-40		85	°C	
RF Frequency Range	$F_{RF}$	902	925	960	MHz	Typical application schematic using the 902 to 960 MHz tuning set ( <b>note 1 &amp; 2</b> ).
RF_IN Port Impedance	$Z_{RFIN}$		50		$\Omega$	
RF_OUT Port Impedance	$Z_{RFOUT}$		50		$\Omega$	

**Note 1:** Operation outside of this range is supported by using different custom tunes. Examples of other optimized tunes can be found here: [GRF5611 Custom Tunes](#)

**Note 2:** Contact the Guerrilla RF Applications team for guidance on optimizing the tuning of the device for alternative bands.



### Nominal Operating Parameters - General

Parameter	Symbol	Specification			Unit	Condition
		Min.	Typ.	Max.		
Supply Quiescent Current	$I_{CCQ}$		207		mA	$I_{CCQ1} + I_{CCQ2}$ . No RF applied.
Supply Current with RF Applied	$I_{CC}$		420		mA	$I_{CC1} + I_{CC2}$ . RF applied. $P_{OUT} = 25$ dBm.
Enable Current 1	$I_{ENABLE1}$		2.5		mA	$V_{CC} = 5$ V.
Enable Current 2	$I_{ENABLE2}$		0.3		mA	$V_{CC} = 5$ V.
Operating Temperature Range	$T_{PKG\ BASE}$	-40		85	°C	Measured on Package Heat Sink.
Logic Input Low	$V_{IL}$	0		0.9	V	Applies to $V_{SHDN}$ Input.
Logic Input High	$V_{IH}$	1.7		$V_{CC}$	V	Applies to $V_{SHDN}$ Input.
Logic Current Low	$I_{IL}$		1.3		nA	Applies to $V_{SHDN}$ Input. $V_{IL} = 0.9$ V.
Logic Current High	$I_{IH}$		65		$\mu$ A	Applies to $V_{SHDN}$ Input, $V_{IH} = 1.8$ V.
			285			Applies to $V_{SHDN}$ Input, $V_{IH} = 3.3$ V.
Switching Rise Time	$T_{RISE}$		500			Applies to $V_{SHDN}$ Input.
Switching Fall Time	$T_{FALL}$		500			Applies to $V_{SHDN}$ Input.

### Disabled Mode

Supply Quiescent Current	$I_{CCQ-SHDN}$		15		$\mu$ A	$V_{CC} = 5$ V, $V_{SHDN}/V_{EN1}/V_{EN2} =$ HIGH.
Enable Current 1	$I_{ENABLE1-SHDN}$		3		$\mu$ A	$V_{CC} = 5$ V, $V_{SHDN}/V_{EN1}/V_{EN2} =$ HIGH.
Enable Current 2	$I_{ENABLE2-SHDN}$		0.75			$V_{CC} = 5$ V, $V_{SHDN}/V_{EN1}/V_{EN2} =$ HIGH.

### Thermal Data (Stage 1 and Stage 2)

See Plot of Die Temp vs. Output Power			TBD			On standard evaluation board.
---------------------------------------	--	--	-----	--	--	-------------------------------

## Nominal Operating Parameters - RF

The following conditions apply unless noted otherwise; Typical Application Schematic,  $V_{CC} = 5\text{ V}$ ,  $F_{TEST} = 925\text{ MHz}$ ,  $50\ \Omega$  system impedance,  $T_{PKG\ BASE} = 25\ ^\circ\text{C}$ . Evaluation board losses are included within the specifications.

Parameter	Symbol	Specification			Unit	Condition
		Min.	Typ.	Max.		
Small Signal Gain	S21		26.3		dB	$F_{TEST} = 925\text{ MHz}$ . $V_{CC} = 5\text{ V}$ . $P_{IN} = -25\text{ dBm}$ .
Standby Mode Gain	S21 <sub>STBY</sub>		-33		dB	Disabled Mode, $V_{SHDN}/V_{EN1}/V_{EN2} = \text{HIGH}$ , $P_{in} = 0\text{ dBm}$ .
Input Return Loss	S11		> 10		dB	$F_{RF} = 902\text{ to }960\text{ MHz}$ .
Output Return Loss	S22		> 6.5		dB	$F_{RF} = 902\text{ to }960\text{ MHz}$ .
Reverse Isolation	S12		> 42		dB	$F_{RF} = 902\text{ to }960\text{ MHz}$ .
Evaluation Board Noise Figure	NF		4.1		dB	
Output 3rd Order Intercept Point	OIP3		46.9		dBm	25 dBm $P_{OUT}$ per tone at 600 kHz Spacing.
Output 1 dB Compression Power	OP1dB		34.9		dBm	Sinewave Input, $V_{CC} = 5\text{ V}$ .
Adjacent Channel Leakage Ratio	ACLR		-46.5		dBc	$P_{OUT} = 25\text{ dBm}$ , LTE 10MHz 50RB TM1.1 Downlink Waveform with 9.6 dB PAR, $V_{CC} = 5\text{ V}$ , $F_{TEST} = 925\text{ MHz}$ ( <b>note 3</b> ).

**Note 3:** Min/Max limits defined using *modelled estimates* that account for part-to-part variations and expected process spreads. As additional production lots are fabricated, accumulated test data will be used to refine the Min/Max limits.



GRF5611 Typical Operating Curves: ACLR vs. P<sub>OUT</sub> (LTE 9.6 dB PAR)

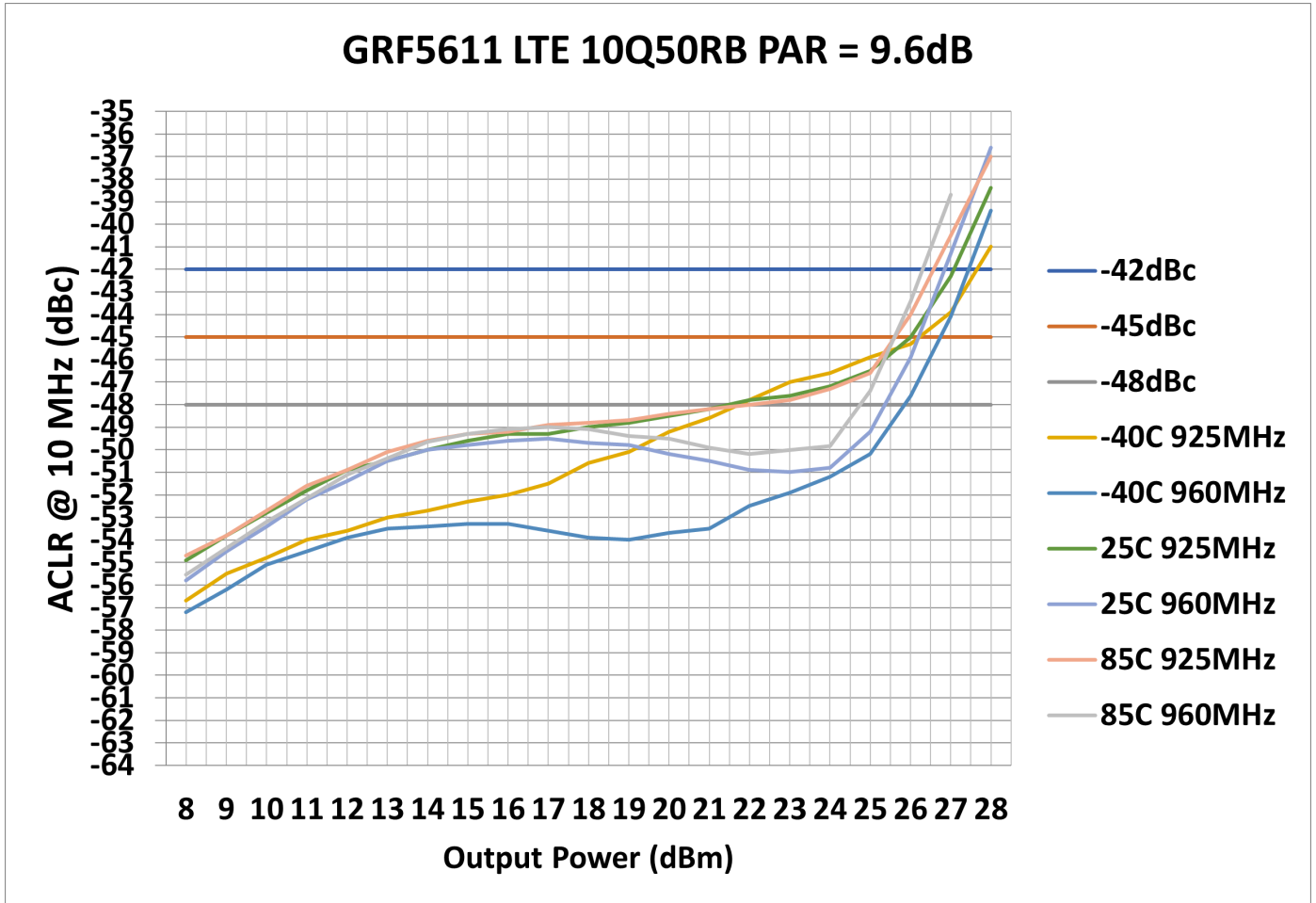

GRF5611 Typical Operating Curves: Stage1 + Stage2 I<sub>CC</sub> vs. P<sub>OUT</sub> (LTE 9.6 dB PAR)

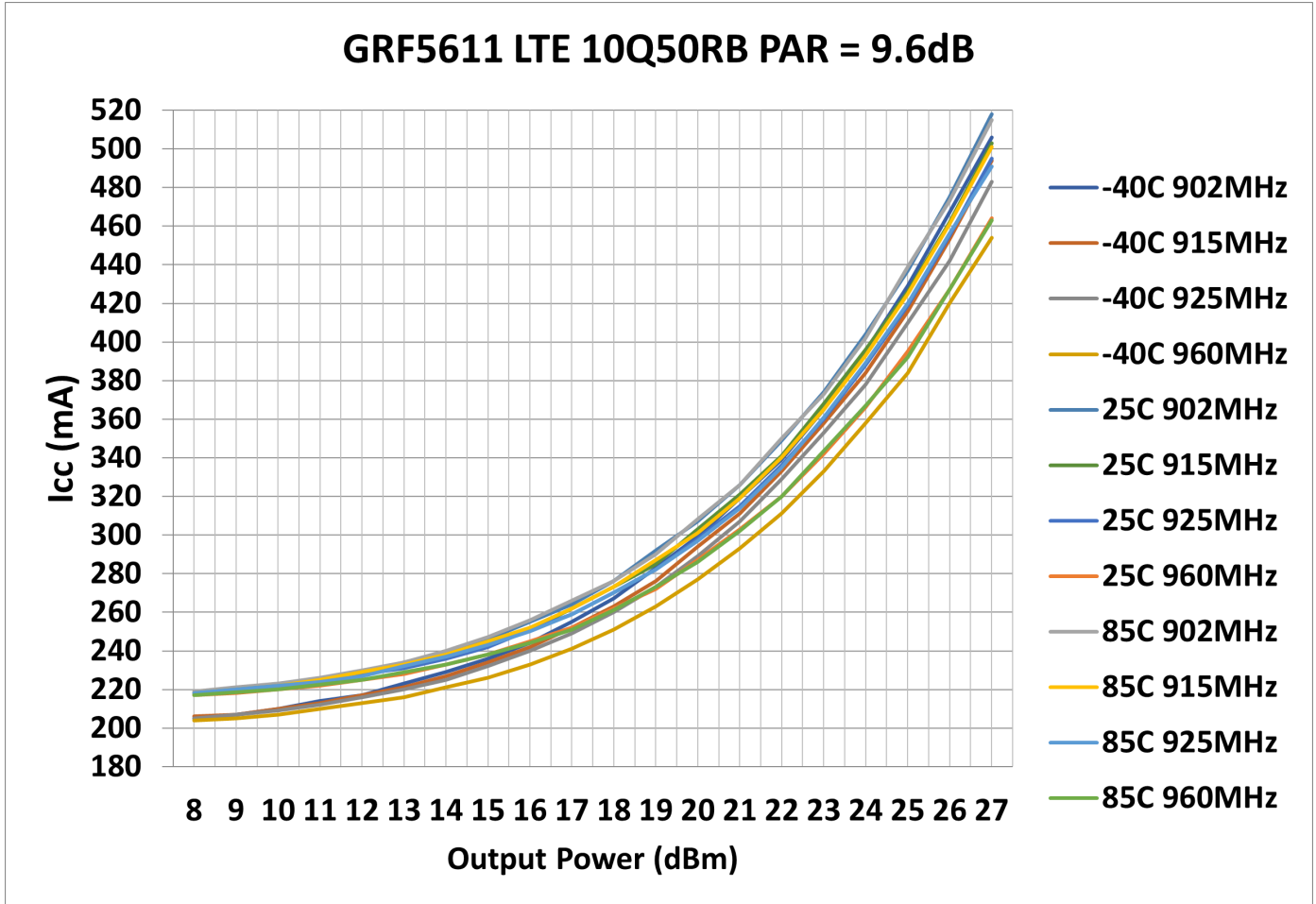

### GRF5611 Typical Operating Curves: S-Parameters (902 to 960 MHz Tune)

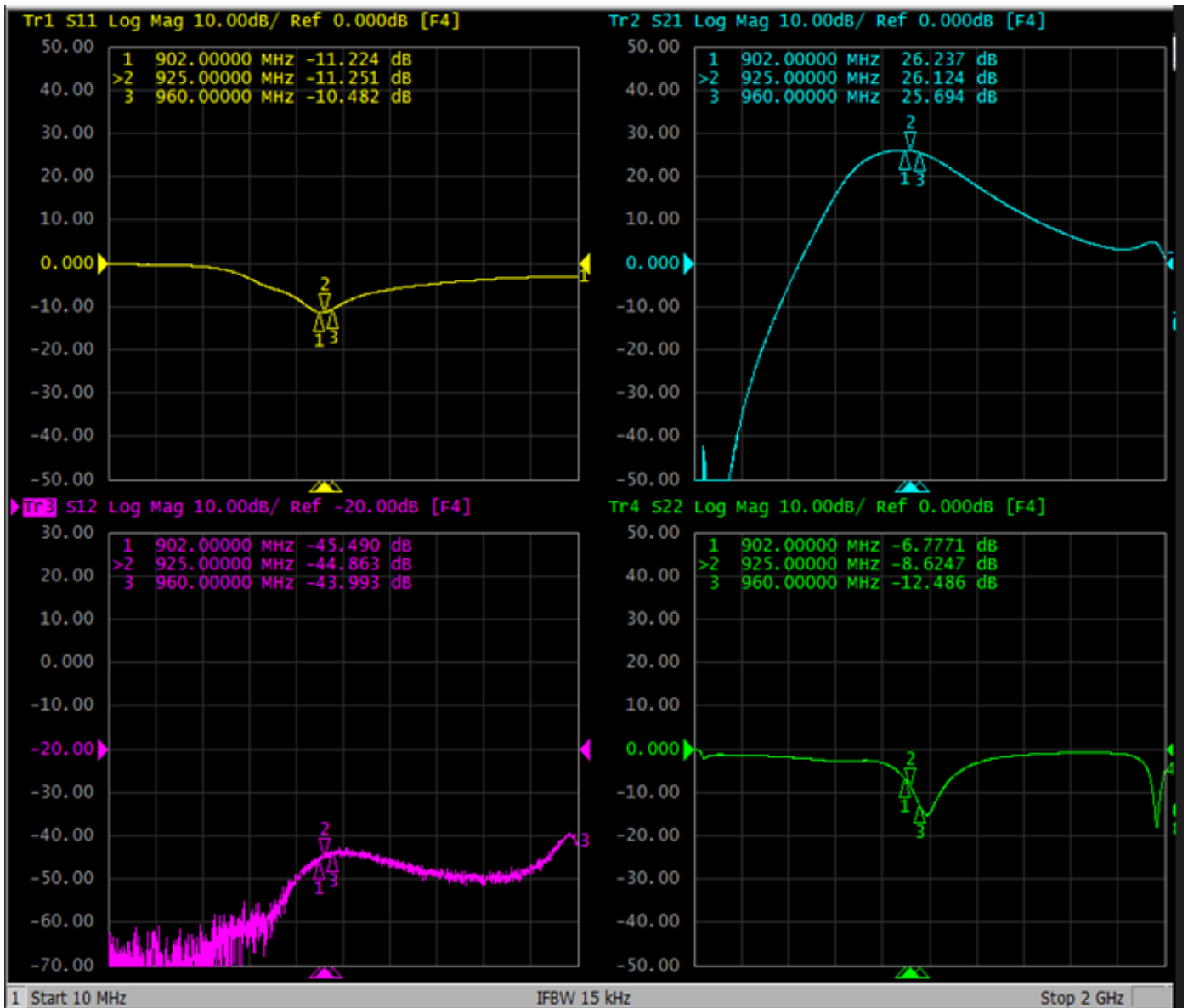

### GRF5611 Typical Operating Curves: Stability Mu (10 MHz to 20 GHz)

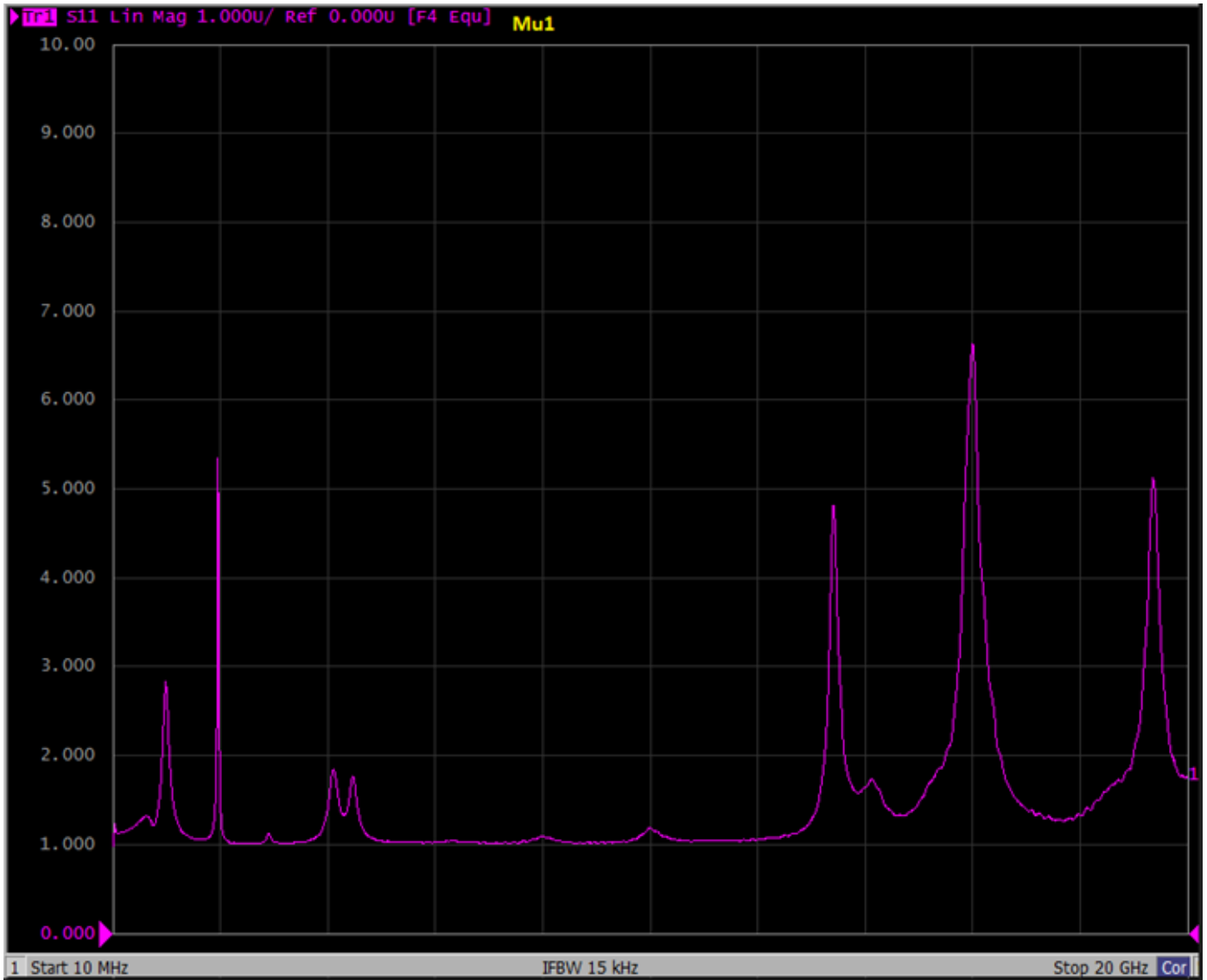

Note: Mu factor  $\geq 1.0$  implies unconditional stability.

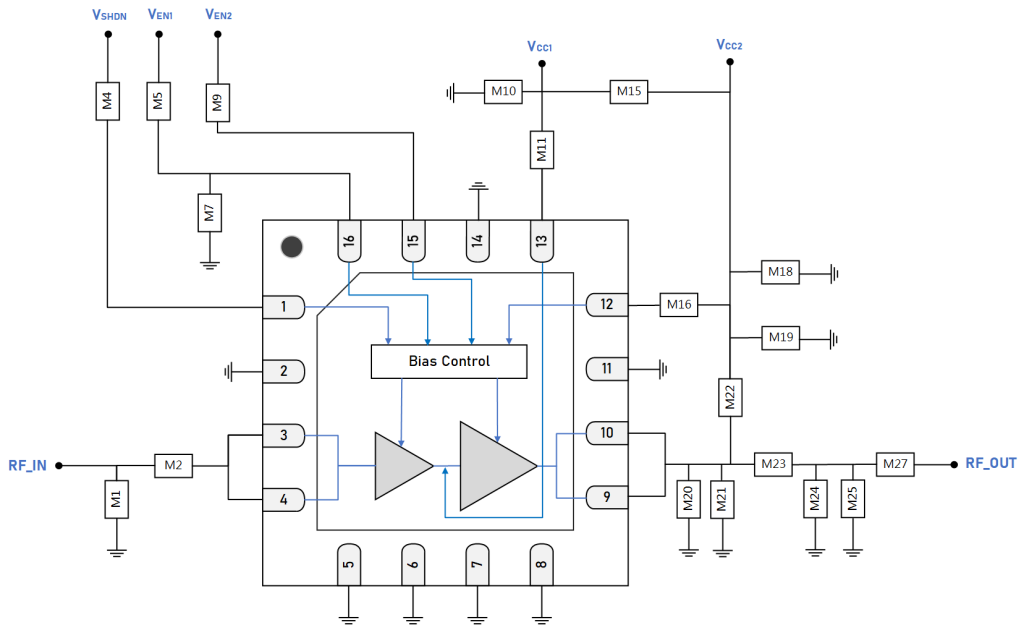

### GRF5611 Standard Evaluation Board Schematic

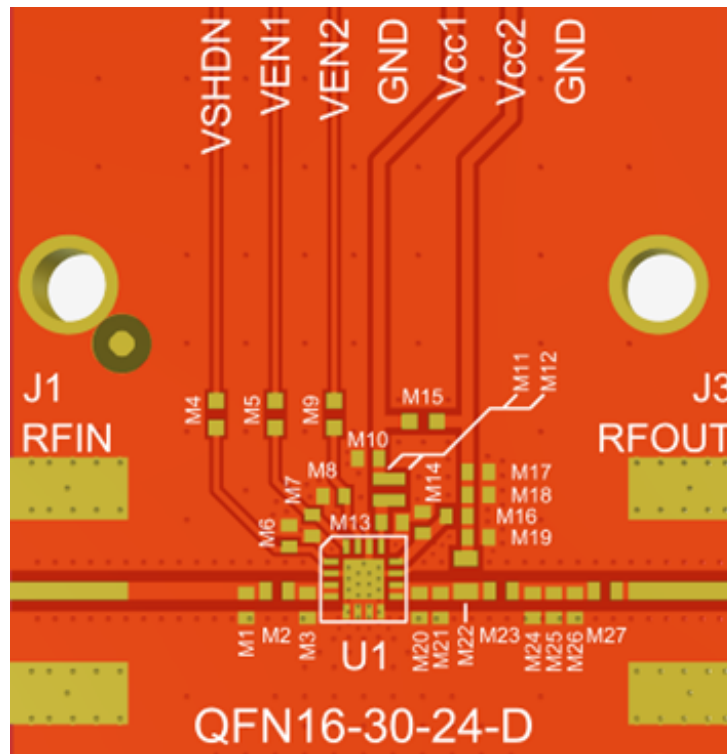

### GRF5611 Evaluation Board Assembly Diagram



## GRF5611 Evaluation Board Assembly Diagram Reference

Component	Type	Manufacturer	Family	Value	Package Size	Substitution
M1	Inductor	Murata	LQG	5.6 nH	0402	ok
M2	Capacitor	Murata	GJM	5.6 pF	0402	ok
M4	Resistor (jumper)	Various	5%	0 $\Omega$	0402	ok
M5	Resistor	Various	1%	1.58 k $\Omega$	0402	ok
M7	Capacitor	Murata	GRM	100 pF	0402	ok
M9	Resistor	Various	1%	6.04 k $\Omega$	0402	ok
M10	Capacitor	Murata	GRM	0.1 $\mu$ F	0402	ok
M11	Inductor	Coilcraft	0402HP	47 nH	0402	ok
M15	Resistor (jumper)	Various	5%	0 $\Omega$	0402	ok
M16	Resistor (jumper)	Various	5%	0 $\Omega$	0402	ok
M18	Capacitor	Murata	**GRM	10 $\mu$ F	0402	ok
M19	Capacitor	Murata	GRM	100 pF	0402	ok
M20	Capacitor	Murata	GJM	5.1 pF	0402	ok
M21	Capacitor	Murata	GJM	4.3 pF	0402	ok
M22	Inductor	Murata	LQW	24 nH	0402	ok
M23	Resistor (jumper)	Various	5%	0 $\Omega$	0402	ok
M24	Capacitor	Murata	GJM	5.6 pF	0402	ok
M25	Capacitor	Murata	GJM	2.7 pF	0402	ok
M27	Capacitor	Murata	GRM	47 pF	0402	ok
Evaluation Board	QFN16-30-24-D					

**Notes:**

Standard evaluation board bias:  $V_{CC} = 5$  V.  $V_{ENABLE} = 5$  V.

\*\* 10  $\mu$ F must be rated for > 5 V at maximum ambient temperature. Manufacturer Part Number in this case = GRM155C80J106ME11D.

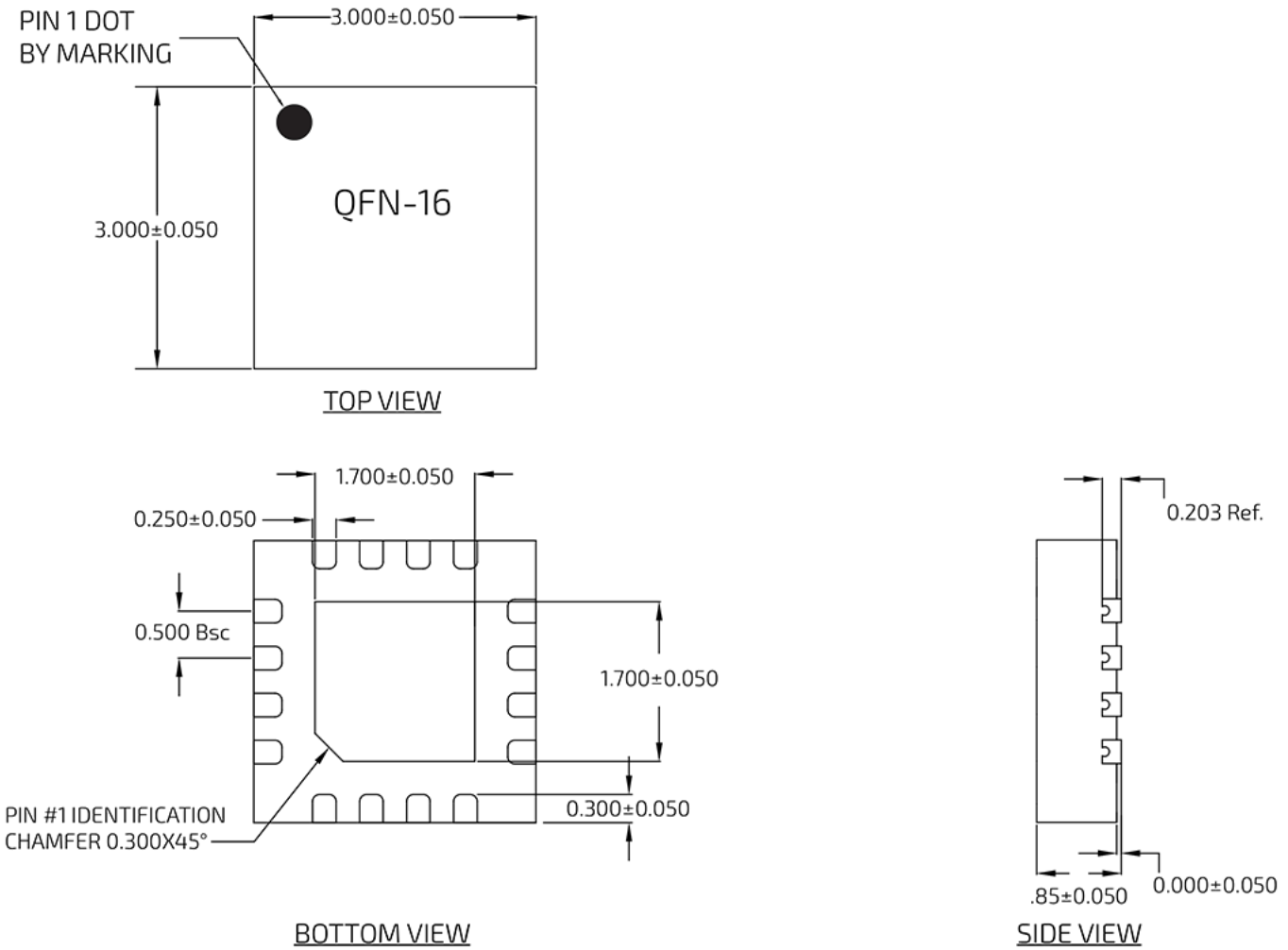

**QFN 16 3x3mm Package Dimensions**

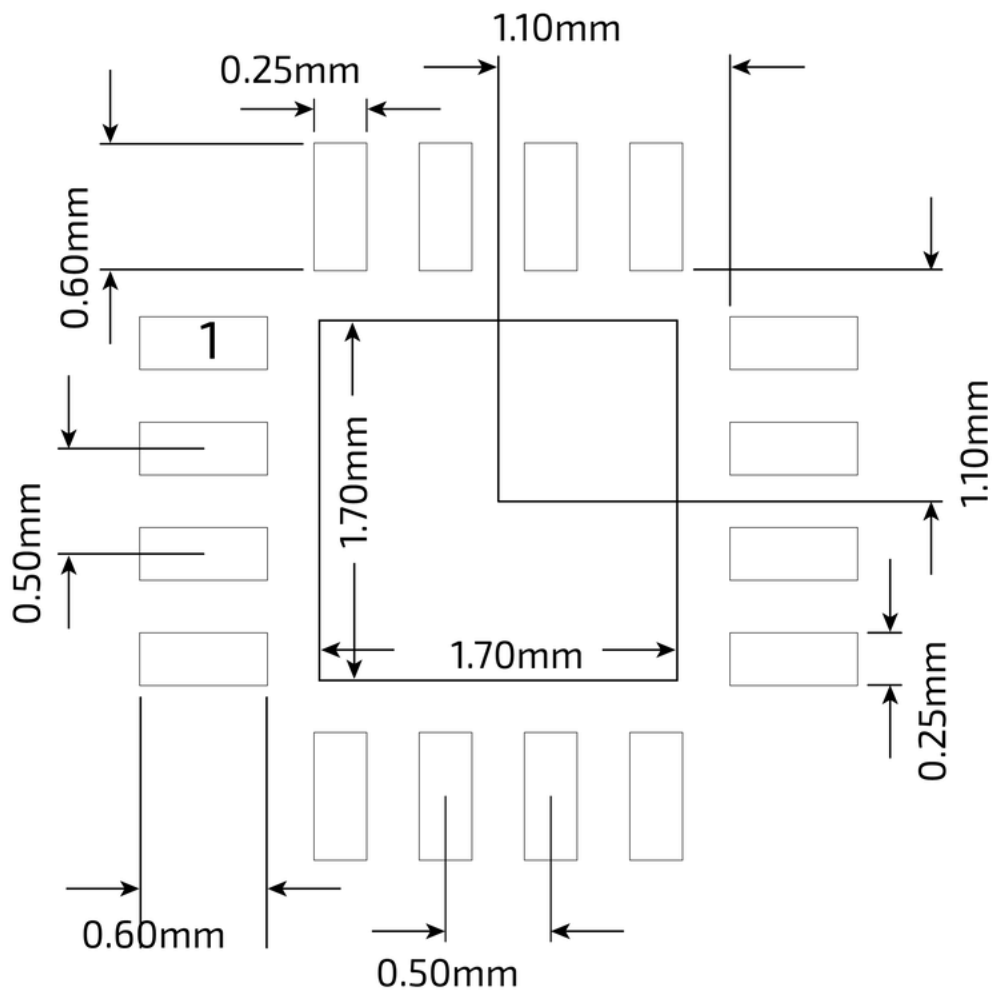

QFN 16 3x3mm Suggested PCB Footprint (Top View)



**Package Marking Diagram**



Line 1: "YY" = Year. "WW" = WORK WEEK the Device was assembled.  
 Line 2: "GRF" = Guerrilla RF  
 Line 3: "XXXX" = Device Part Number.

**Tape and Reel Information**

Guerrilla RF's tape and reel specification complies with Electronics Industries Association (EIA) standards for "Embossed Carrier Tape of Surface Mount Components for Automatic Handling" (reference EIA-481). Devices are loaded with pins down into the carrier pocket with protective cover tape and reeled onto a plastic reel. Each reel is packaged in a cardboard box. There are product labels on the reel, the protective ESD bag, and the outside surface of the box. For the latest reel specifications and package information (including units/reel), please visit [Package Manufacturing Information](#) | [Guerrilla RF](#) (guerrilla-rf.com).

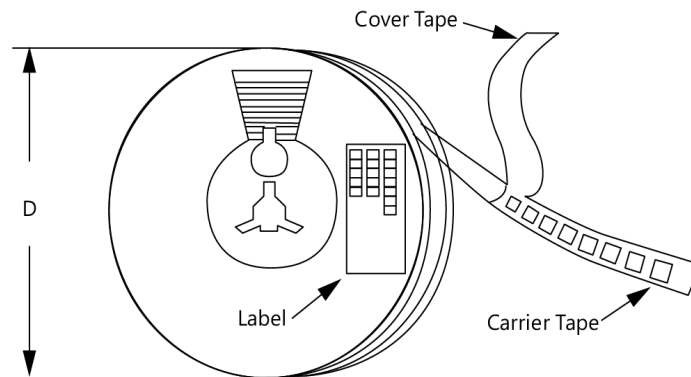

Tape and Reel Packaging with Reel Diameter Noted (D)

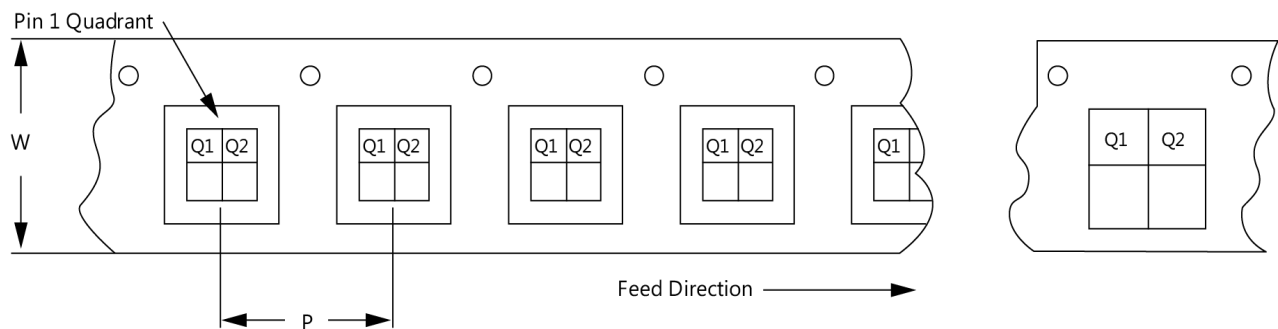

Carrier Tape Width (W), Pitch (P), Feed Direction and Pin 1 Quadrant Information



**Revision History**

<b>Revision Date</b>	<b>Description of Change</b>
January 10, 2023	Preliminary Data Sheet.
September 20, 2023	Upgraded Data Sheet to newest format only.
June 12, 2025	Page 1: updated lower frequency range for GRF5608 and GRF5610.



Data Sheet Classifications

Data Sheet Status	Notes
Advance	S-parameter and NF data based on EM simulations for the fully packaged device using foundry-supplied transistor S-parameters. Linearity estimates based on device size, bias condition and experience with related devices.
Preliminary	All data based on evaluation board measurements taken within the Guerrilla RF Applications Lab. Any MIN/MAX limits represented within the data sheet are based solely on <i>estimated</i> part-to-part variations and process spreads. All parametric values are subject to change pending the collection of additional data.
Release Ø	All data based on measurements taken with <i>production-released</i> material. TYP values are based on a combination of ATE and bench-level measurements, with MIN/MAX limits defined using <i>modelled estimates</i> that account for part-to-part variations and expected process spreads. Although unlikely, future refinements to the TYP/MIN/MAX values may be in order as multiple lots are processed through the factory.
Release A-Z	All data based on measurements taken with production-released material <i>derived from multiple lots which have been fabricated over an extended period of time</i> . MIN/MAX limits may be refined over previous releases as more statistically significant data is collected to account for process spreads.

Information in this data sheet is specific to the Guerrilla RF, Inc. ("Guerrilla RF") product identified.

This data sheet, including the information contained in it, is provided by Guerrilla RF as a service to its customers and may be used for informational purposes only by the customer. Guerrilla RF assumes no responsibility for errors or omissions on this data sheet or the information contained herein. Information provided is believed to be accurate and reliable, however, no responsibility is assumed by Guerrilla RF for its use, nor for any infringement of patents, or other rights of third parties, resulting from its use. Guerrilla RF assumes no liability for any data sheet, data sheet information, materials, products, product information, or other information provided hereunder, including the sale, distribution, reproduction or use of Guerrilla RF products, information or materials.

No license, whether express, implied, by estoppel, by implication or otherwise granted by this data sheet for any intellectual property of Guerrilla RF, or any third party, including without limitation, patents, patent rights, copyrights, trademarks, and trade secrets. All rights are reserved by Guerrilla RF.

All information herein, products, product information, data sheets, and data sheet information are subject to change and availability without notice. Guerrilla RF reserves the right to change component circuitry, recommended application circuitry and specifications at any time without prior notice. Guerrilla RF may further change its data sheet, product information, documentation, products, services, specifications or product descriptions at any time, without notice. Guerrilla RF makes no commitment to update any materials or information and shall have no responsibility whatsoever for conflicts, incompatibilities, or other difficulties arising from any future changes.

GUERRILLA RF INFORMATION, PRODUCTS, PRODUCT INFORMATION, DATA SHEETS AND DATA SHEET INFORMATION ARE PROVIDED "AS IS" AND WITHOUT WARRANTY OF ANY KIND, WHETHER EXPRESS, IMPLIED, STATUTORY, OR OTHERWISE, INCLUDING FITNESS FOR A PARTICULAR PURPOSE OR USE, MERCHANTABILITY, PERFORMANCE, QUALITY OR NON-INFRINGEMENT OF ANY INTELLECTUAL PROPERTY RIGHT; ALL SUCH WARRANTIES ARE HEREBY EXPRESSLY DISCLAIMED. GUERRILLA RF DOES NOT WARRANT THE ACCURACY OR COMPLETENESS OF THE INFORMATION, TEXT, GRAPHICS OR OTHER ITEMS CONTAINED WITHIN THESE MATERIALS. GUERRILLA RF SHALL NOT BE LIABLE FOR ANY DAMAGES, INCLUDING BUT NOT LIMITED TO ANY SPECIAL, INDIRECT, INCIDENTAL, STATUTORY, OR CONSEQUENTIAL DAMAGES, INCLUDING WITHOUT LIMITATION, LOST REVENUES OR LOST PROFITS THAT MAY RESULT FROM THE USE OF THE MATERIALS OR INFORMATION, WHETHER OR NOT THE RECIPIENT OF MATERIALS HAS BEEN ADVISED OF THE POSSIBILITY OF SUCH DAMAGE.

Customers are solely responsible for their use of Guerrilla RF products in the Customer's products and applications or in ways which deviate from Guerrilla RF's published specifications, either intentionally or as a result of design defects, errors, or operation of products outside of published parameters or design specifications. Customers should include design and operating safeguards to minimize these and other risks. Guerrilla RF assumes no liability or responsibility for applications assistance, customer product design, or damage to any equipment resulting from the use of Guerrilla RF products outside of stated published specifications or parameters.